

**MODELS:**  
 MSIPV4-17JS-Px  
 MSIPV4-17ES-Px  
 MSIPV4-17VS-Px  
 MSIPV4-17GS-Px  
 MSIPV4-17JA-Px (Audio In)  
 MSIPV4-17EA-Px (Audio In)  
 MSIPV4-17VA-Px (Audio In)  
 MSIPV4-17GA-Px (Audio In)

**Made in Japan**

**Px**  
 Series

**5.0 / 3.0 Mega-Pixel**

Thank you for your purchase of this product.  
 Before attempting to connect or operate this product, please read these instructions completely.  
 The above drawing is for reference only.

**FEATURES**

- 3.0 Mega-pixel CMOS Sensor (MSIPV4-17JS-Px / MSIPV4-17VA-Px)
- 3.0 Mega-pixel Sony Sensor (MSIPV4-17ES-Px / MSIPV4-17EA-Px)
- 5.0 Mega-pixel CMOS Sensor (MSIPV4-17VS-Px / MSIPV4-17VA-Px)
- 5.0 Mega-pixel Sony Sensor (MSIPV4-17GS-Px / MSIPV4-17GA-Px)
- MSIPV4-17JA-Px (Audio In)
- MSIPV4-17EA-Px (Audio In)
- MSIPV4-17VA-Px (Audio In)
- MSIPV4-17GA-Px (Audio In)
- 2.8~12 mm Vari-Focal Motorized lens,
- True Day/Night with ICR,
- (VCA) Temper Detection & ROI
- High contrast image at night with customized optical components
- Hybrid SMT IR LED,
- Max. 5~35 meters true Night Vision Distance, Ultra clear image at night without dark corner

**PACKAGE CONTENTS**

1. IP CAMERA - 1 pcs.
2. SCREW - 3 pcs.
3. WALL PLUG - 3 pcs.
4. QUICK SETUP GUIDE - 1 pcs.

**CAUTION**

**CAUTION**  
 DO NOT OPEN  
 RISK OF ELECTRIC SHOCK

**CAUTION**  
 TO REDUCE THE RISK OF ELECTRIC SHOCK, DO NOT REMOVE COVER (OR BACK), NO USER SERVICEABLE PARTS INSIDE. REFER SERVICING TO QUALIFIED SERVICE PERSONNEL.



The lightning flash with arrowhead symbol, within an equilateral triangle, is intended to alert the user to the presence of uninsulated dangerous voltage within the product's enclosure that may be sufficient magnitude to constitute a risk of electric shock to a person.



The exclamation point within an equilateral triangle is intended to alert the user to the presence of important operating and maintenance (servicing) instructions in literature accompanying the appliance.

**PRECAUTIONS**

1. Do not attempt to disassemble the camera.
2. Handle the camera with care.
3. The installation should be made by qualified service personnel or system installers.
4. Do not use strong or abrasive detergents when cleaning the camera body.
5. Clean the CMOS faceplate with care.
6. Never face the camera towards the sun.
7. Use the camera at temperatures within -10 °C to +50 °C, and humidity below 90 % RH and the storage temperatures should be within -20 °C to +60 °C and humidity below 20% to 80 % RH.
8. Please operate the camera within the specified power source ratings. Avoid connections during a lightning storm. Otherwise, an electric shock may be caused.

**CAUTION:** Camera supplied with factory set Fixed Focal Lens. Do not change focus, any attempt to change lens focus may not give correct focus image at Day or Night. Do not attempt to disassemble the camera. Any attempt to disassemble the camera may hamper the waterproof ability of the camera.

**INSTALL PREPARATION**

1. Installation and maintenance should be carried out by professional personnel as per relative regulations. All electrical work must obey the latest electrical regulations, fire regulations and relevant regulations. Check whether the accessories of the unit are complete according to packing list and confirm whether the place and method of installation is in accord with required, if not, please contact your supplier. Please use this product in required environment.
2. This IP camera is designed for outdoor / indoor use.
3. After re-installation or repair, you need to measure the resistance between the circuit and shell to check whether the insulation is good and ensure there is no short-circuit between the circuit and shell.
4. Confirm there is enough place to contain the product and its structural components. Confirm the ceiling, wall and bracket for installation can take the total weight of the product and its structural components, and materials used to support the weight can sustain four times the weight of the product.
5. Please check the product package well. You can send the IP camera to factory with that package if there is any problem that needs to service.

**CAMERA CONNECTION**

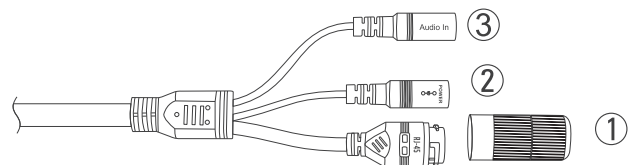

- ① Network interface + POE
- ② DC
- ③ Audio - In MSIPV4-17JA-Px / MSIPV4-17VA-Px

**Network Interface**

Connect the network interface using RJ 45 network cable. It shows working when the network indicator is on.

**12 V DC Power Supply**

Connect the 12 Volt DC / 1.0 Amp power using DC Jack. Please make sure the polarity is correct. Incorrect polarity may cause malfunction and/or damage to the camera.

**Wiring Precautions**

Do not bend the UTP cable into a curve whose radius is smaller than 10 times the cable's diameter.

Never staple the cable even if with circular staples. Otherwise impedance mismatching will occur.

PRODUCTS IMAGE



INSTALLATION OF CAMERA

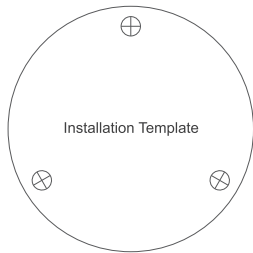

MOUNTING TEMPLATE STICKER

The mentioned technical drawing is for Reference only. Actual size of Mounting Template Sticker is matched with Dome Base.

1. Stick Mounting Template Sticker supplied for drilling the mounting hole on the mounting surface. The unit is intended to be mounted with three #10 screws through the three outer holes at the base of dome camera.
2. Install the appropriate anchors or threaded fasteners.

DIMENSIONS

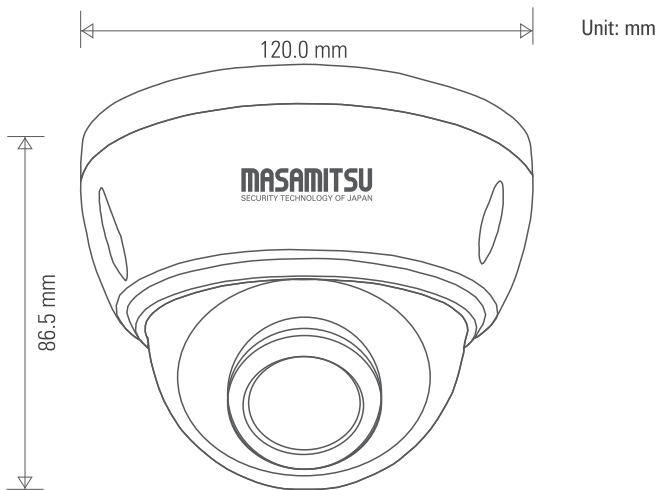

The above mentioned technical drawings are for reference only. All dimensions are in millimeters and approximate.



TECHNICAL SPECIFICATIONS

Model Name	MSIPV4-17JS-Px MSIPV4-17JA-Px (A.In)	MSIPV4-17ES-Px MSIPV4-17EA-Px (A.In)	MSIPV4-17VS-Px MSIPV4-17VA-Px (A.In)	MSIPV4-17GS-Px MSIPV4-17GA-Px (A.In)
<b>VIDEO PARAMETERS</b>				
Imaging Device	1/2.7" Progressive Scan CMOS Sensor	1/2.7" Progressive Sony IMX307 Sensor	1/2.7" Progressive Scan CMOS Sensor	1/2.7" Progressive Sony IMX335 Sensor
Total Pixels	2,048(H)X1,536(V)	2,048(H)X1,536(V)	2,560(H)X1,960(V)	2,560(H)X1,960(V)
Scanning System	Progressive Scan Sensor			
Min. Illumination	Color: 0.1Lux@F1.2 (AGC OFF), B/W: 0.0Lux@F1.2 (IR ON)			
S/N Ratio	More than 50 dB (AGC OFF)			
Video Compression	H.265, H.264, M-JPEG			
Video Quality	H.265, H.264: Compression Level, Target Bit rate Level Control (CBR/VBR), M-JPEG: Quality Level Control			
Data Rate Control	Video Compression level of H.265, H.264, Video Frame rate, Bit rate CBR or VBR			
Dual Stream	Main Stream: 2048*1536/1920*1080 / 1280*720 Sub Stream: 704*576/640*480/320*240	Main Stream: 2048*1536/1920*1080 / 1280*720 Sub Stream: 704*576/640*480/320*240	Main Stream: 2560*1960/2592*1520/2048*1536/1920*1080 Sub Stream: 704*576/640*480/320*240	Main Stream: 2560*1960/2592*1520/2048*1536/1920*1080 Sub Stream: 704*576/640*480/320*240
Max. Frame rate	2048X1536@20fps; 1920X1080@25fps; 1280X960@25fps	2048X1536@20fps; 1920X1080@25fps; 1280X960@25fps	2560X1960@15fps; 2592X1520@25fps; 2048X1536@25fps	2560X1960@15fps; 2592X1520@25fps; 2048X1536@25fps
<b>LENS PARAMETER</b>				
Lens Type	2.8~12 mm Vari-Focal Motorized Lens (All models)			
<b>OTHER FUNCTIONS</b>				
WDR (Two Exposure)	NA			
Digital WDR	Support All Models			
Day&Night	True Day Night with ICR			
DNR	3DNR			
Motion Detection	4 Area Selectable Support			
Privacy Masking	4 Area Selectable Support			
Gain Control	Max. AGC to 255			
White Balance	Auto White Balance (AWB)			
Electronic Shutter	Auto/A.FLK/Manual			
Flip/Mirror	Support All Models			
<b>IR PARAMETERS WITH SELECTION OF LENS</b>				
2.8~12 mm Lens	Split Beam 60° Customized SMT IR LED			
IR Distance & Lens	2.8~12 mm lens(5~35 mt.)			
<b>NETWORK PARAMETERS</b>				
Ethernet	RJ45 for 10BASE-T/100BASE-TX PoE			
Audio	1 RCA Audio In-Puts ( Model : MSIPV4-17VA-Px / MSIPV4-17EA-Px / MSIPV4-17JA-Px / MSIPV4-17GA-Px )			
Protocol	HTTP, PPPoE, UPNP, FTP, DDNS, VPN, RTSP, etc.			
ONVIF Conformance	Support ONVIF Profile S Ver.2.4			
CMS Software	Support			
<b>ENVIRONMENTAL PARAMETERS</b>				
Temperature/ Humidity	-10°C to +50°C , 0% to 90% (non-condensing)			
Ingress Protection	Waterproof Housing (Ip66) / Vandal Proof Dome			
<b>ELECTRICAL PARAMETERS</b>				
Power over Ethernet	Power over Ethernet IEEE 802.3af Class 2			
Input Voltage/ Current	190mA/DC12V; 330mA/DC12V with IR LED ON			
Power Consumption	Day:1.92W Night:3.96W			
<b>MECHANICAL PARAMETERS</b>				
Color/ Material	Body: White Epoxy Spray Paint / Aluminum Dai Cast / PC Dome Cover			
Dimensions	120.0 mm (B) X 86.5 mm (H)			
Weight	Approx. 500 g			

Quick Installation Setup

Web Browser camera Activation.

1. Power on the camera . and connect camera to the network .
2. The default IP address of the camera is 192.168.1.101
3. Input the default IP address of the camera into the address bar of the web browser, Following window will appear

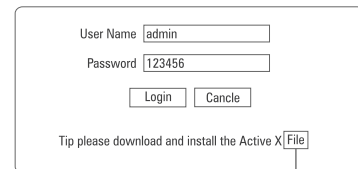

Default User Name is  download active X  
Default Password

4. **STRONG PASSWORD** we recommend after enter the camera menu one should change the password and keep strong Password ( using a minimum of 8 characters, including upper case letters, numbers, and special characters )
5. Various parameters of the Ip camera can be selected or change using the camera GUI ( Graphic User Interface )
6. User can modify the IP address according to there requirement of LAN setting.
7. After changing the IP address of your network camera and if some how you forgot the assigned IP address in that case a search tool is in the CD.

**8 NOTE :- For detail operating Manual , please see PDF files in the CD provided along with the Camera .**